



cGator High-Power Known Good Die Contactor

High-Power Known Good Die Contactor

for SiC and GaN Wide Bandgap High-Voltage
and High-Current KGD applications



Applications

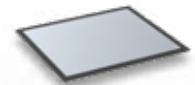

Power Diodes

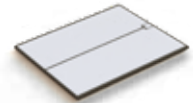

Power MOSFET



Power IGBT

End Product Markets

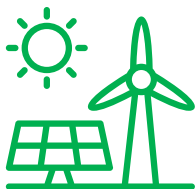

Green Energy
Power Management



xEV
Electrification



Industrial
Power Applications

Key Features

- cGator contactor is a top and bottom contacting solution for power KGD chips
- Cohu's Volta-Flux MEMS probe architecture technology provides stable and low CRES for very challenging high-voltage and high-current requirement
- The gentle-touch feature reduces surface impacts to a minimum while providing a reliable contact force
- The Volta-Flux high-power density solution enables efficient heat dissipation also from top and bottom surface of the die under test
- MEMS probe technology enables smart stacking of pins to increase current carrying capability

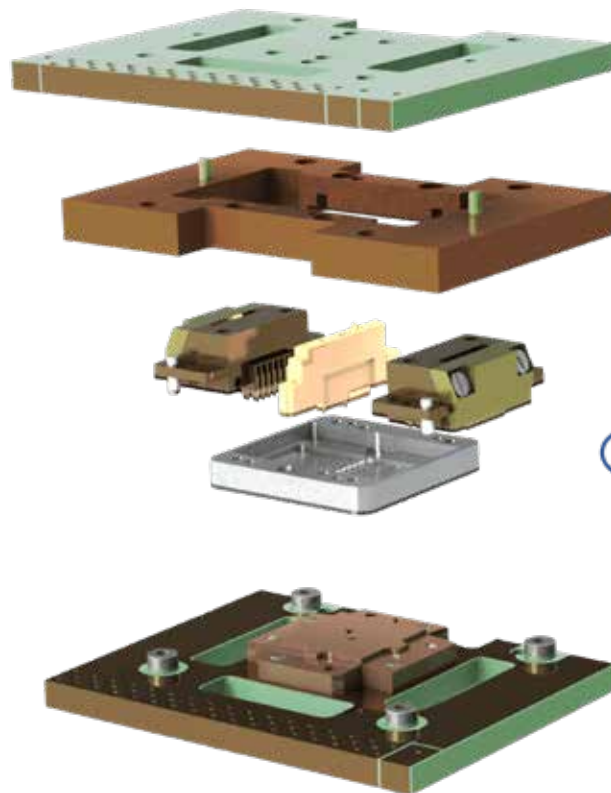

Key Test Parameter

- High-voltage static parameter tests up to 3,000 V
- Unclamped Inductive Switching Test (UIS) – Avalanche Test
- Dynamic switching test up to 1,000 A
- Low stray inductance enables fast dynamic switching test signal interface

Possible Surface Metalizations

- Aluminum (Alloy) Oxide
- Palladium
- Copper
- Silver/Gold
- And others



All specifications are subject to change without notification and are for reference only. Use contactor drawing to design interface hardware. For detailed performance specifications, please contact Cohu.